



FOR MESSRS : _____

CUSTOMER'S ACCEPTANCE SPECIFICATIONS

MAGNETRON : 2M286-21TAG

DATE :JAN, 05, 2020

CONTENTS

● COVER	1
● RECORD OF REVISION	2
● TEST SPECIFICATIONS	3
● CHARACTERISTIC CHART	7
● DIMENSIONAL OUTLINE	9
● LABEL	10
● MATERIAL AND STRUCTURE	11
● FILTER BOX	12
● MOUNTING ON LAUNCHER	13
● TEST EQUIPMENT	15

SIGNATURES : _____
PROPOSED BY

SIGNATURES : _____
APPROVED BY

RECORD OF REVISION

Rev. No	DATE	REVISION CONTENTS	SHEET NO.
0	JAN, 05, 2020	-	-

TEST SPECIFICATIONS

Description : Continuous Wave Magnetron, 2460MHz, Fixed Frequency

1. Absolute Maximum Ratings :

	Symbol	Min	Max	Unit	Note
Filament Voltage	Ef	2.70	3.60	Vac	
Pre-heating Time	tk	0	-	sec	
Average Anode Current	Ib	-	380	mAdc	
Peak Anode Current	ibm	-	1.5	Ap	
Peak Anode Voltage	ebm	-	4.85	kVp	
Average Anode Input	pi	-	1.7	kW	
Load VSWR (continuous)	σ L	-	4	-	(15)
Anode Core Temperature	Tp	-	300	°C	(3)
Filter Case Temperature	Tcase	-	120	°C	
Antenna Temperature	Ta	-	360	°C	
Storage Temperature	-	-30	60	°C	
Filament Ceramic Temperature	Tc	-	190	°C	(18)

2. General Test Condition :

	Symbol	Value
Filament Voltage	Ef	3.15 Vac
Pre-heating Time	tk	8 sec
Average Anode Current	Ib	330 mAdc
Load VSWR	σ L	1.1 Max
Cooling Air Flow	Q	1.0 m ³ /min
Test Equipment		Page 14~ 15/15
Power Supply	single-phase, full-wave rectifier without filter

3. Test Specifications :

Item	Symbol	Nominal	Min	Max	Unit	Note
*Filament Current (individual spec)	If	10.5	8.0	12.0	Aac	
Peak Anode Voltage	ebm	4.40	4.15	4.60	kVp	(5)
Average Output Power	Po	1040	980	1100	W	(5)
Frequency	fo	2460	2450	2470	MHz	

Test Specifications (Continued) :

Item	Symbol	Nominal	Min	Max	Unit	Note
** Sink Phase (at $\sigma L=4$)	l_o/λ_g	0.30	0.27	0.33	-	(6)
** Pulling Figure (at $\sigma L=4$)	fp_l	40	-	48	MHz	(6)
* Stability (at $\sigma L \leq 4$)	(STIb)	-	300	-	mAdc	(10)(13)
Breakdown Voltage	(Et)	-	10	-	kVdc	(14)
(Raising voltage gradually, positive potential to anode : RL=100 K Ω)						
* Insulation (Et=1000Vdc)	Rpf	-	100	-	M Ω	
* Leakage microwave	p_l	-	-	1	mW/cm ²	(7)(8)
(with 275ml water load, at 5cm from magnetron)						
* Vibration Test	-	-	-	-	-	(2)(12)
** Mechanical strength (A)	-	-	4	-	kg	(9)
** Mechanical strength (B)	-	-	3	-	kg	(9)
** Mechanical strength (C)	-	-	10	-	kg	(9)
* Surge voltage	(epo)	-	-	10	kVp	(8)(11)(14)

Notes :

- (1) "EIAJ-ED-1501/(old)ET-145 Testing methods for continuous wave magnetron" by Electronic Industries Association of Japan, is referred.
- (2) Breaking of filament should not be observed.
- (3) Maximum rating for short time operation is given as follows.
 1. 330 °C ----- Allowable at an operating for within 15 minutes
(cumulated operating time should be within 50 hours)
 2. 380 °C ----- Allowable at an operating for within 15 minutes
(one time only)
- (4) Classification of tests is given as follows.

Mark	Class
None	Production test
*	Design test
**	Type approval test

Marks are at the left of each test item.
(ex. *Surge voltage)

Notes (continued) :

(5) These limits are defined as converted values to 25 °C

Conversion should be done using the equation shown below.

$$ebm(T) = \{1 - 0.002(T - 25)\} \cdot ebm$$

$$Po(T) = \{1 - 0.002(T - 25)\} \cdot Po$$

(Where, $ebm(T)$, $Po(T)$: Values at ambient temperature $T(^{\circ}C)$)

(6) pulling figure is the difference between the maximum and the minimum frequency of oscillation that occurs when the phase of the reflection coefficient of the load is varied over the $\lambda g/2$.

The sink phase is defined as the phase to give maximum change of the frequency and to give the same oscillating frequency as that at matched load.

In both cases, with the variation of phase, the load VSWR should be held at the stated value ($\sigma L=4$)

(7) Measured with Narda type 8110 radiation monitor.

(8) Measured with the microwave oven accepted by both parties.

(9) Mechanical strength (A)

: The antenna cover should not be drawn out when it is pulled to the direction of antenna axis with stated force.

Mechanical strength (B)

: Any degradation of breakdown voltage should not be observed after pressing the filter box with standard test finger with stated force.

Mechanical strength (C)

: The terminals should withstand stated pulling force to the direction of terminal axis.

(10) Any instability such as moding if run-away should not be observed at any load phase.

(11) Filament terminal with in-phase mark ("F") should be connected to the filament transformer so as to have the same polarity as anode.

(12) Test conditions are as follows.

Amplitude : 2 mm (peak to peak)

Frequency : 25 Hz

Time of vibration : 10 minutes (for each of three directions)

(13) Distance from reference place of magnetron (antenna axis) to mismatched point should be 27.6 inches (700mm) min.

(14) Should not discharge continuously.

(15) Load match may vary to higher VSWR in application, but must be reviewed by LG with regard magnitude, phase and dwell time.

Notes (continued) :

- (16) The filament current at high frequency operation shall be defined by effective value.
- (17) The filament current at any conditions shall be in this specification.
It is not to include the rushed filament current during warm-up (approx. 5 seconds)
The oven shall be cold state before the test starts.
- (18) The filament ceramic temperature is follows as belows.
- ① Load : 1,000cc water in 1,000cc beaker.
 - ② Allowable at an operating for within 20 minutes
 - ③ Test Point is below picture
- Down stream air(center of ceramic)

CHARACTERISTIC CHART

1. PERFORMANCE CHART

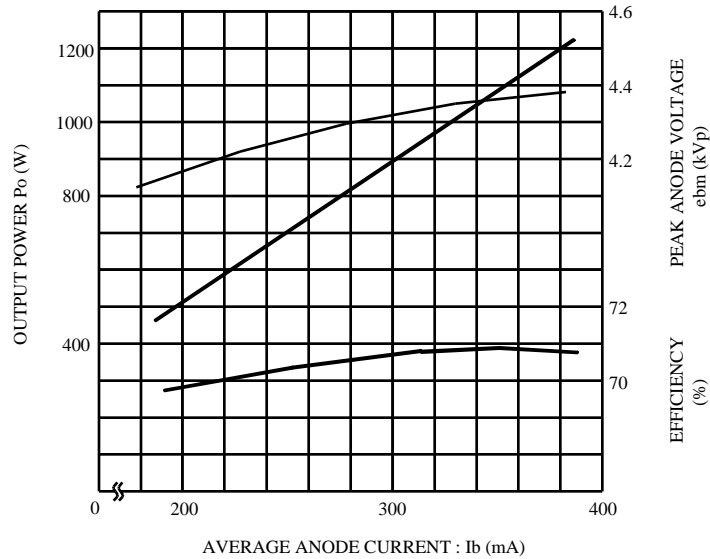

OPERATING CONDITIONS :

POWER SUPPLY SINGLE PHASE FULL-WAVE RECTIFIER
 WITHOUT FILTER
 LOAD : MATCHED LOAD ($\sigma \leq 1.1$)
 FILAMENT VOLTAGE : 3.15V

2. TYPICAL RIEKE DIAGRAM

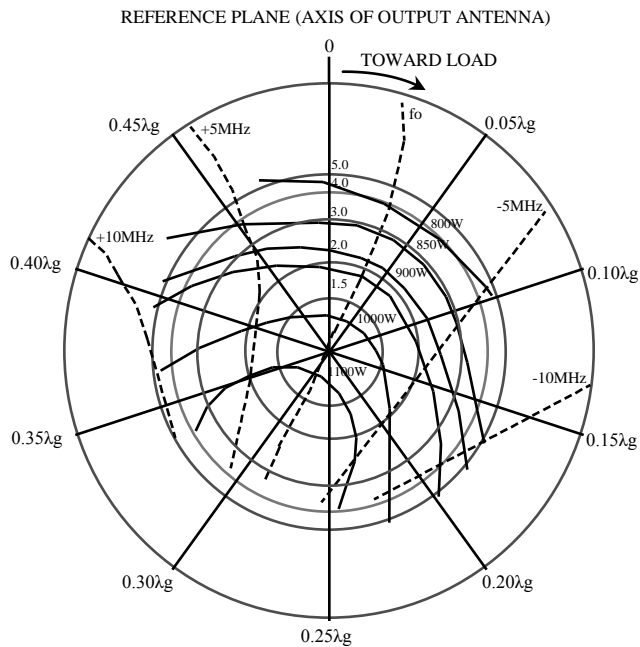

OPERATING CONDITIONS :

POWER SUPPLY SINGLE PHASE,
 FULL-WAVE RECTIFIER WITHOUT FILTER
 AVERAGE ANODE CURRENT 330 mA
 WAVE GUIDE : LG STANDARD LAUNCHER.

————— OUTPUT POWER (W)
 - - - - - FREQUENCY (MHz)

3. ANODE DISSIPATION VS ANODE TEMPERATURE RISE

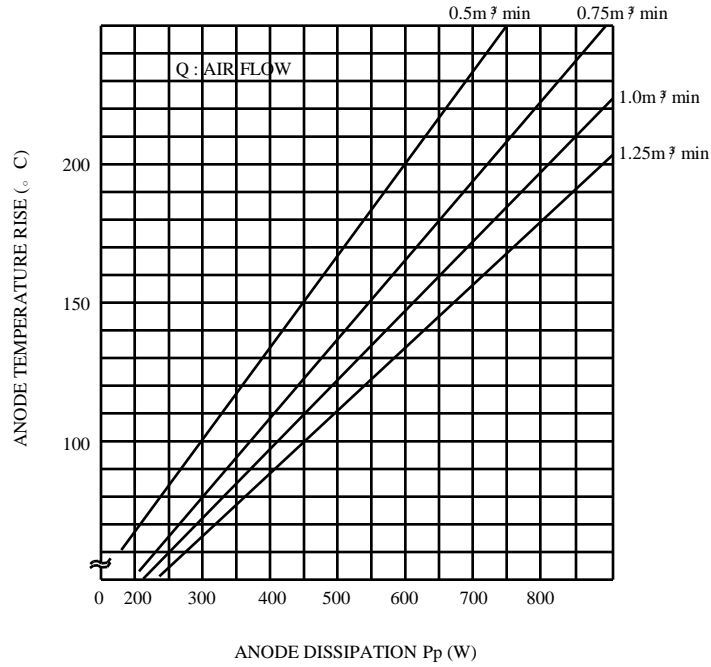

4. AIR FLOW VS STATIC PRESSURE DROP

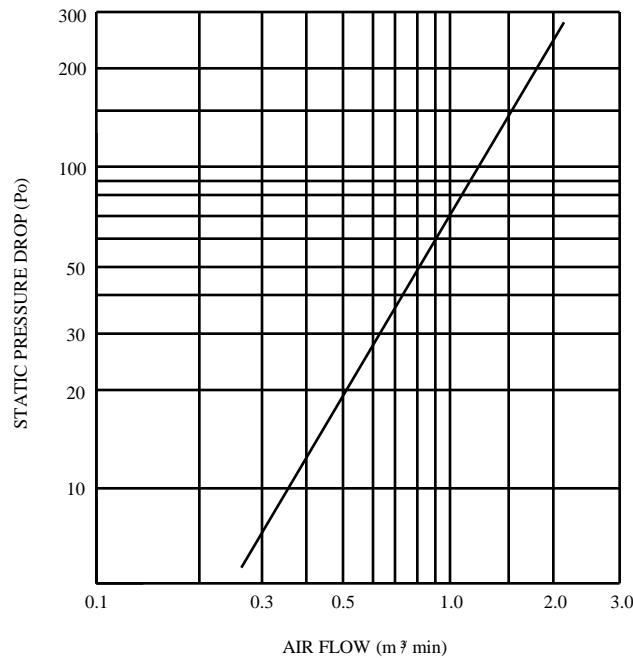

DIMENSIONAL OUTLINE OF 2M286

DIMENSIONS IN MILLIMETERS

2M286-21TAG TYPE

NOTE :

1. ADAPTABLE TO FASTON 250 SERIES RECEPTACLE.
2. ANODE TEMPERATURE MEASURING POINT.
(DOWN STREAM AIR)
3. CASE TEMPERATURE MEASURING POINT.
4. ANTENNA TEMPERATURE MEASURING POINT.
5. ADDED QR CODE ON CONDENSER

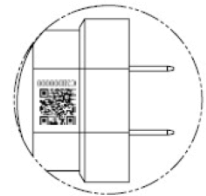
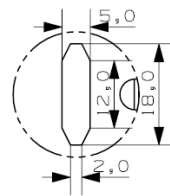
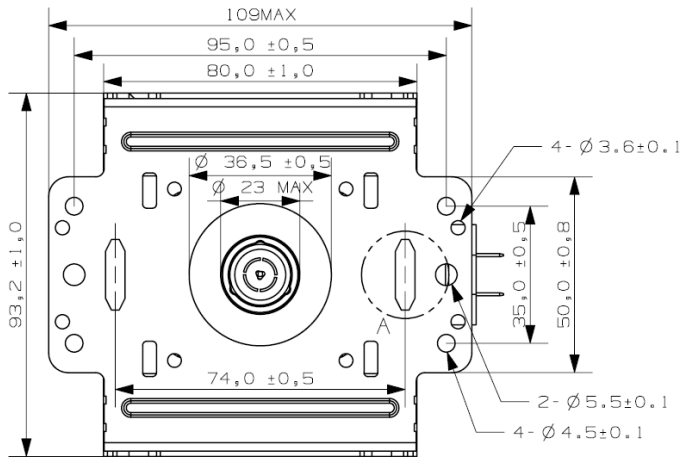

NOTE(5) 2-Dimension code

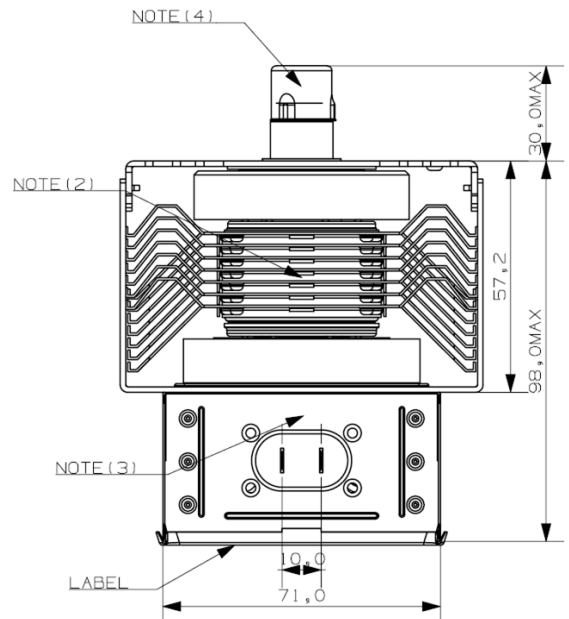
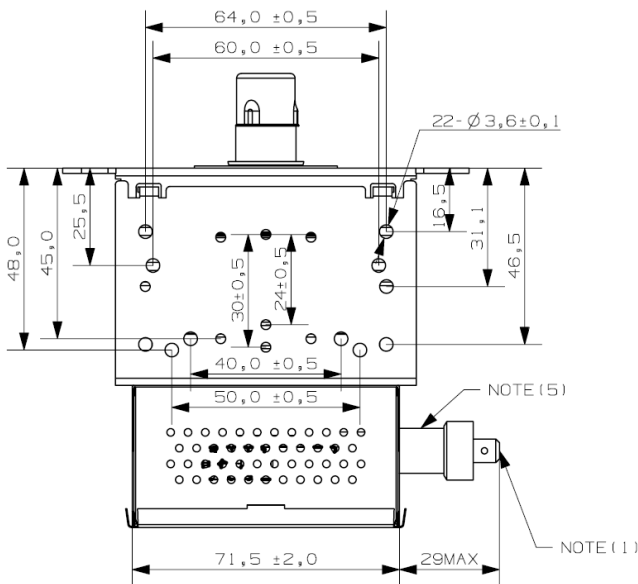

LABEL SPECIFICATION

DIMENSIONS IN MILLMETERS

40

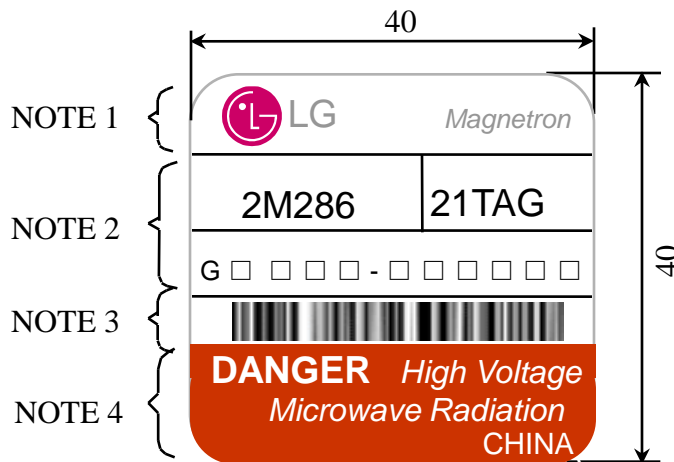

NOTE :

1. It indicates LG brand with symbol mark and Magnetron.
2. It indicates Magnetron's model name.
Below is each model's serial number.
3. It indicates the bar code with Magnetron information.
4. It indicates 'Danger' and The origin of a product.

Area indicated to be red with white letters.

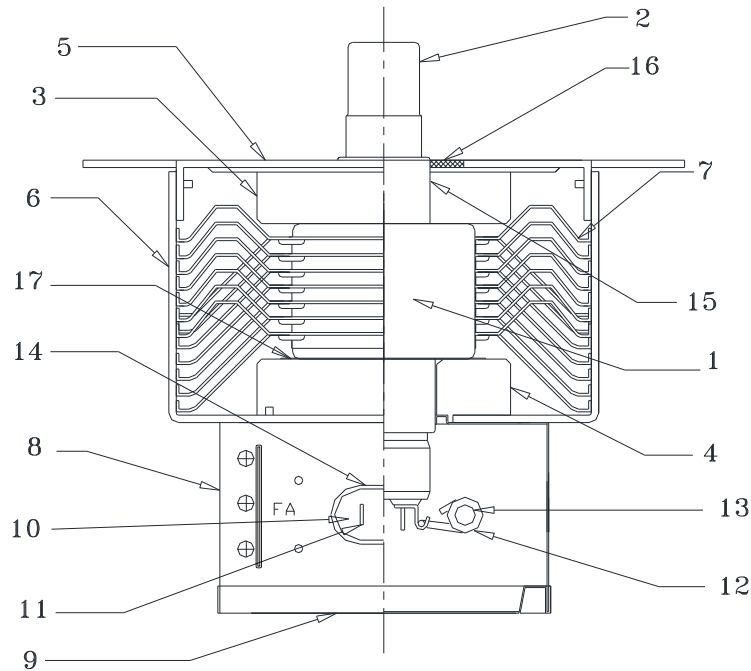
2M286 MATERIAL AND STRUCTURE

NO	PART NAME	MATERIAL	NOTE
1	VACUUM TUBE	(2M286)	
2	ANTENNA CAP	STAINLESS STEEL	
3	MAGNET	Sr FERRITE	12.4t, Φ55 x Φ21.0
4	MAGNET	Sr FERRITE	12.2t, Φ60.5 x Φ21.0
5	YOKE	STEEL (ZINC PLATED)	t1.4mm
6	YOKE	STEEL (ZINC PLATED)	t1.4mm
7	FIN	ALUMINUM	t0.6 x 80 x 90.2, 7pcs
8	FILTER BOX	STEEL (ZINC PLATED)	BENDING t 0.4 x 71 x 71 x 37.5
9	FILTER BOX (LID)	STEEL (ZINC PLATED)	t0.3mm
10	CAPACITOR	BaTi ₃ (EPOXY RESIN MOLDED) 10KVdc 500PF×2	TDK/PARTRON
11	TAB	Copper	
12	CHOKE COIL	COPPER WIRE Φ1.6 ×5.6 TURNS 0.4μH	
13	CORE	FERRITE	Φ8.6 x 14
14	COVER	POLYETHYLENE - TELEPHALATE	
15	BASE	STAINLESS STEEL or STEEL (ZINC PLATED)	
16	GASKET	BRASS	t1.5mm
17	MAGNET SPACER	STEEL (ZINC PLATED)	Φ50 x Φ22 x t0.3

INSULATING DISTANCES IN THE FILTER BOX

DIMENSIONS IN MILLIMETERS

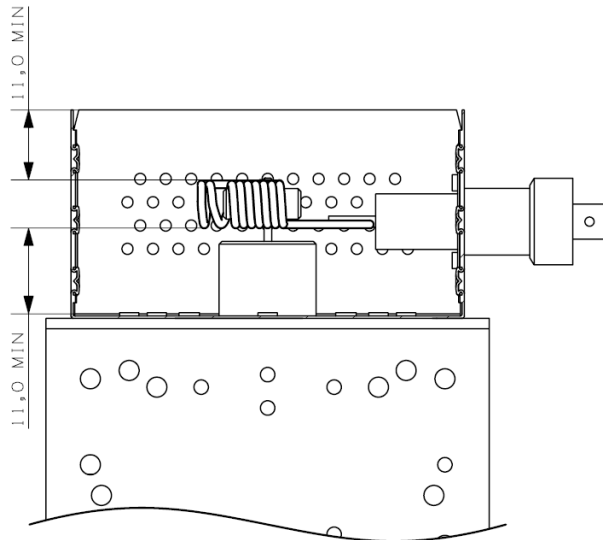
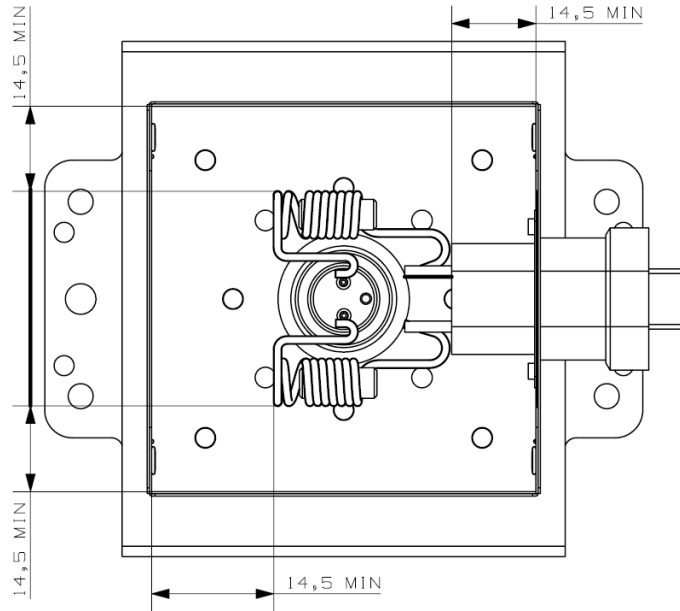

MOUNTING ON LAUNCHER

DIMENSIONS IN MILLIMETERS

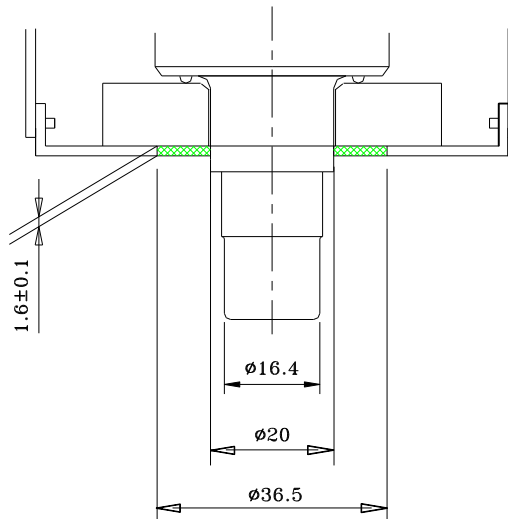

NOTE : 1. This figure is without gasket.

2. Recommended structure of launcher

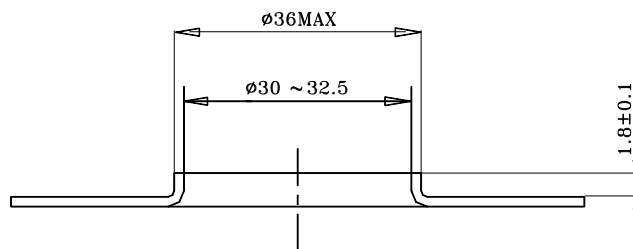

NOTE :

1. Flatness of embossed edge should be better than 0.1mm to avoid microwave leakage.
2. Recommended pressure on gasket is 20 to 40kg.

LAUNCHER AND TAPERED WAVEGUIDE FOR TESTING

DIMENSIONS IN MILLIMETERS
(IN INCHES)

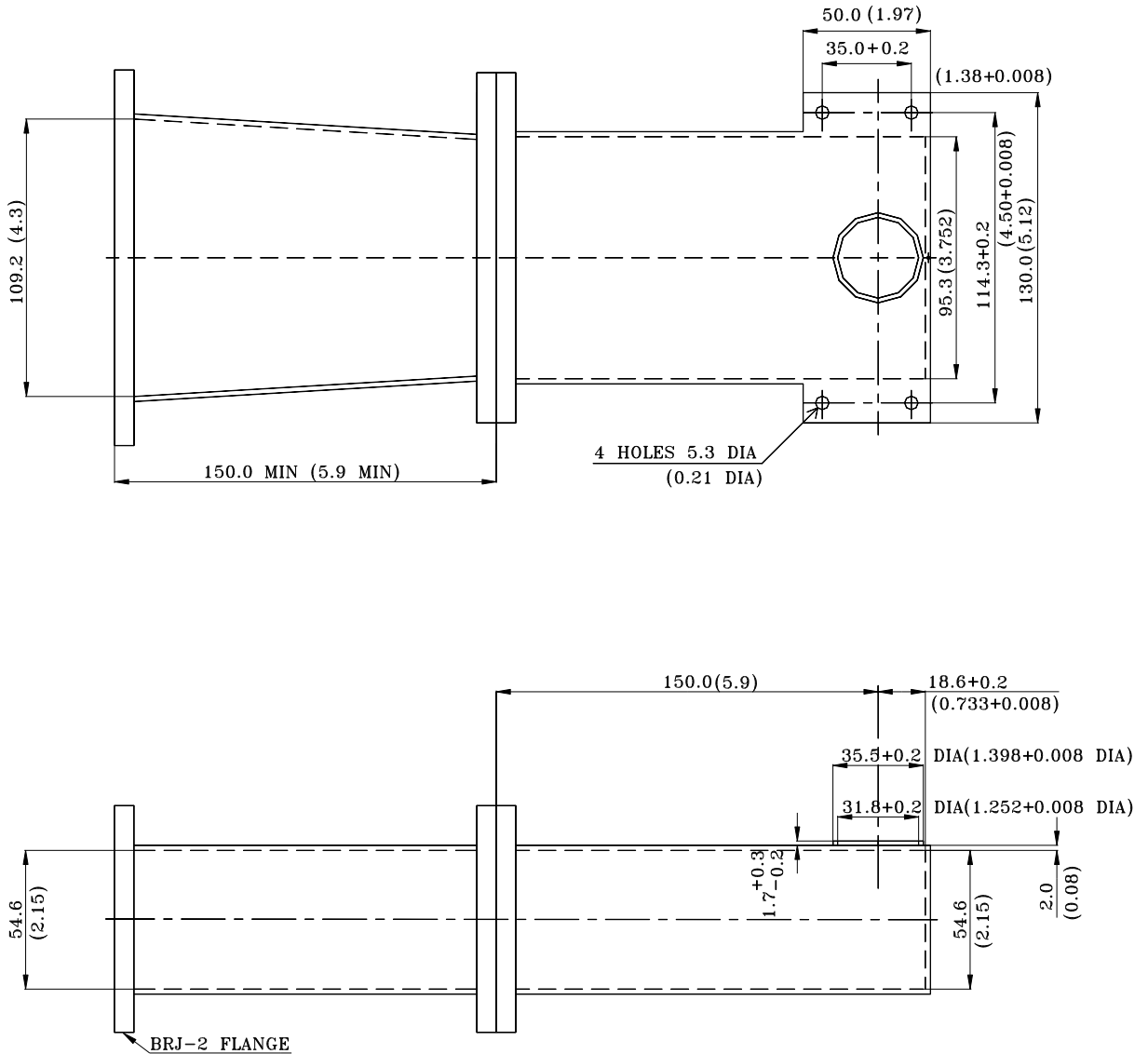

BLOCK DIAGRAM OF TEST EQUIPMENT